



12 TON AC OPERATING AND SERVICE MANUAL



TARTING S/N AC012-20-00001
REV -

TABLE OF CONTENTS

Page No.	Description
1	Table of Contents
2	Safety Information
5	Technical Data Specifications
6	Operator Control Panel
8	Operation and Service
9	Troubleshooting
10	Electrical Schematic
11	Electrical Panel Layout
12	Piping Layout
13	Structural\Sheet Metal BOM

Important Safety Information

Most accidents that involve product operation, maintenance and repair are caused by failure to observe basic safety rules or precautions. An accident can often be avoided by recognizing potentially hazardous situations before an accident occurs. A person must be alert to potential hazards, including human factors that can affect safety. This person should also have the necessary training, skills and tools to perform these functions properly.

Improper operation, lubrication, maintenance or repair of this product can be dangerous and could result in injury or death.

Do not operate or perform any lubrication, maintenance or repair on this product, until you verify that you are authorized to perform this work, and have read and understood the operation, lubrication, maintenance, and repair information.

Safety precautions and warnings are provided in this manual and on the product. If these hazard warnings are not heeded, bodily injury or death could occur to you or to other persons.

The hazards are identified by the "Safety Alert Symbol" and followed by a "Signal Word" such as "DANGER", "WARNING" or "CAUTION". The Safety Alert "WARNING" label is shown below.



The meaning of this safety alert symbol is as follows:

Attention! Become Alert! Your Safety is involved.

The message that appears under the warning explains the hazard and can be either written or pictorially presented.

A non-exhaustive list of operations that may cause product damage are identified in this publication.

TCRS cannot anticipate every possible circumstance that might involve a potential hazard. The warnings in this publication and on the product are, therefore, not all inclusive. You must not use this product in any manner different from that considered by this manual without first satisfying yourself that you have considered all safety rules and precautions applicable to the operation of the product in the location of use, including site-specific rules and precautions applicable to the worksite. If a tool, procedure, work method or operating technique that is not specifically recommended by TCRS is used, you must satisfy yourself that it is safe for you and for others. You should also ensure that you are authorized to perform this work, and that the product will not be damaged or become unsafe by the operation, lubrication, maintenance or repair procedures that you intend to use.

The information, specifications, and illustrations in this publication are on the basis of information that was available at the time that the publication was written. The specifications, torques, pressures, measurements, adjustments, illustrations, and other items can change at any time. These changes can affect the service that is given to the product. Obtain the complete and most current information before you start any job.



When replacement parts are required for this product, TCRS recommends using parts with equivalent specifications including, but not limited to, physical dimensions, type, strength and material.

Failure to heed this warning can lead to premature failures, product damages, personal injury or death.

Universal Warning



WARNING

Do not operate or work on this equipment unless you have read and understand the instructions and warnings in the Operation and Maintenance Manuals. Failure to follow the instructions or heed the warnings could result in serious injury or death.

Electrical Shock

The safety message for electrical shock is located on the control panel.

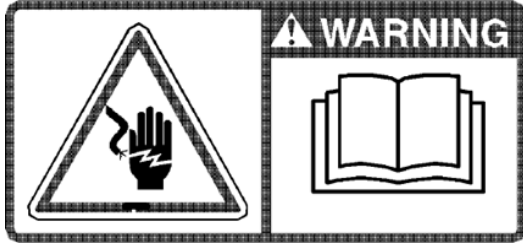

WARNING

WARNING! Shock/Electrocution Hazard! Read and understand the instructions and warnings in the Operation and Maintenance Manual. Failure to follow the instructions or heed the warnings could cause serious injury or death.

Additional Messages

There are several warning labels on this unit. Please be aware of all warning labels.

Make sure that all of the messages are legible. Clean the messages or replace the messages if the words or images are unreadable. When you clean the messages, use a cloth, water and soap. Do not use solvent, gasoline, or other harsh chemicals to clean the messages. Solvents, gasoline, or harsh chemicals could loosen the adhesive that secures the messages. Loose adhesive will allow the messages to fall off.

Replace any message that is damaged, or missing. If a message is attached to a part that is replaced, install a message on the replacement part.

General Hazard Information

Attach a “Do Not Operate” warning tag to the start switch or controls before the unit is serviced or repaired. Attach the warning tags to the unit and to the operator control station. When appropriate, disconnect the starting controls. Do not allow unauthorized personnel on the unit, or around the unit when the unit is being serviced. Cautiously remove the following parts. To help prevent spraying or splashing of pressurized fluids, hold a rag over the part that is being removed.

- Gage ports
- Breathers
- Drain plugs



Use caution when cover plates are removed. Gradually loosen, but do not remove the last two bolts or nuts that are located at opposite ends of the cover plate or the device. Before removing the last two bolts or nuts, pry the cover loose in order to relieve any spring pressure or other pressure.

Wear a hard hat, protective glasses, and other protective equipment, as required. Do not wear loose clothing or jewelry that can snag on parts of the unit. Ensure that all protective guards and all covers are secured in place on the unit. Never put maintenance fluids into glass containers. Glass containers can break. Use all cleaning solutions with care. Report all necessary repairs.

Unless other instructions are provided, perform maintenance under the following conditions:

The unit is powered down and cannot be started.

The protective locks on the controls are in the locked out position.

Do not attempt any repairs that are not understood. Use the proper tools.

Replace any equipment that is damaged or repair the equipment.

Pressurized Air and Water

Pressurized air and/or water can cause debris and/or hot water to be blown out which could result in personal injury. The maximum air pressure for cleaning purposes must be reduced to 205 kPa (30 psi) when the air nozzle is deadheaded and used with effective chip guarding (if applicable) and personal protective equipment. The maximum water pressure for cleaning purposes must be below 275 kPa (40 psi). When pressurized air and/or pressurized water is used for cleaning, wear protective clothing, protective shoes, and eye protection. Eye protection includes goggles or a protective face shield. Always wear eye protection for cleaning the cooling system. Avoid direct spraying of water on electrical connectors, connections, and components. When using air for cleaning, allow the machine to cool to reduce the possibility of fine debris igniting when redeposited on hot surfaces.

Fluid Penetration

Always use a board or cardboard when you check for a leak. Leaking fluid that is under pressure can penetrate body tissue. Fluid penetration can cause serious injury and possible death. A pinhole leak can cause severe injury. If fluid is injected into your skin, you must get treatment immediately. Seek treatment from a doctor that is familiar with this type of injury.

Containing Fluid Spillage

Care must be taken to ensure that fluids are contained during performance of inspection, maintenance, testing, adjusting, and repair of the product. Be prepared to collect the fluid with suitable containers before opening any compartment or disassembling any component containing fluids. Dispose of all fluids according to local regulations and mandates.

Dispose of Waste Properly

Improperly disposing of waste can threaten the environment. Potentially harmful fluids should be disposed of according to local regulations. Always use leak proof containers when you drain fluids. Do not pour waste onto the ground, down a drain, or into any source of water.

Burn Prevention

Do not service an operating unit. Allow the compressor to cool before any maintenance is performed.

Technical Data Specifications

Model Number	AC12TON
Serial Number	AC012-20-00001
Capacity	144,000 BTUH
Voltage	480V 3PH 60Hz
FL Amps - Cooling	35 AMPS
Interrupt Rating	10KAIC
Minimum Circuit	50 AMPS
Enclosure Type	Type 3R
Control	110V
Control	24V DC
Compressor	
H.P.	20 HP
FLA	24.3 AMPS
Circuit Protection	27 AMPS
Condenser Fan Motor	
WATTS	2700 WATTS
FLA	4 AMPS
Circuit Protection	10 AMPS
Blower Motor	
WATTS	3100 WATTS
FLA	4.85 AMPS
Circuit Protection	10 AMPS
Condensate Pump	
H.P.	1/150 HP
FLA	1 AMP
Circuit Protection	2 AMPS
Control Transformer	
Rating	500 VA
Primary Fuse	ATDR4
Secondary Fuse	ATDR4
Refrigerant	R-410A
Charge	12 LBS.
High Press Cut Out	575 PSIG
Low Press Cus Out	75 PSIG
Oil	Bitzer BVC32 180oz.
DBA @20'	73 DBA
Weight	1150 LBS.

Made in USA

Operator Control Panel

Main Disconnect Switch – Turns main power on to the entire system and is protected by the main circuit breaker.

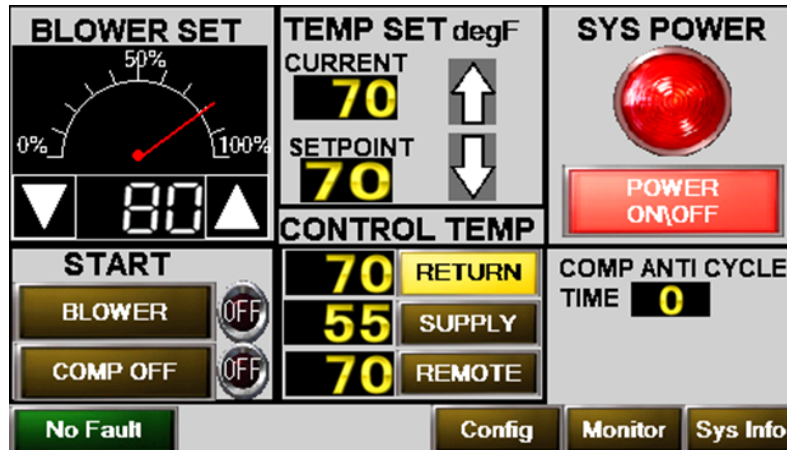

HMI MAIN screen - Control system functions.

POWER ON\OFF touch button – Enable System Power and control.

BLOWER SET touch setting – Set blower speed from 50% to 100%

TEMP SET touch setting- Set desired temperature setpoint.

RETURN, SUPPLY, REMOTE touch button – Select which sensor will be monitored.

BLOWER touch button – Start blower.

COMP ON\OFF touch button – Start\stop compressor.

FAULT touch button – Red when fault is active, press to display Fault screen.

Config touch button – Password protected to set initial system settings.

Monitor touch button – Press to display Monitor screen.

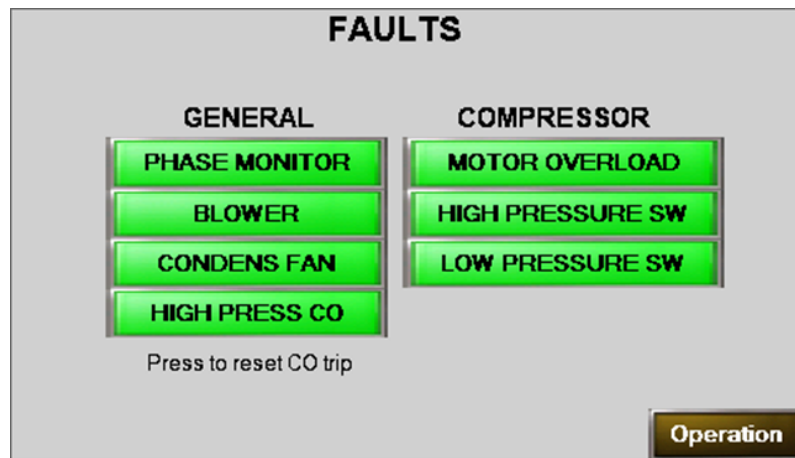

FAULT Screen

Fault indication lights turn red when fault is active and stop system operation.

PHASE MONITOR - Main power phasing and phase loss status.

BLOWER - Blower motor status.

CONDENS FAN – Condenser motor status.

HIGH PRESS CO – System pressure above High Pressure Cut Out.

MOTOR OVERLOAD – Compressor status.

HIGH PRESSURE SW – System pressure above limit, tripped mechanical switch.

LOW PRESSURE SW – System pressure below limit, tripped mechanical switch.

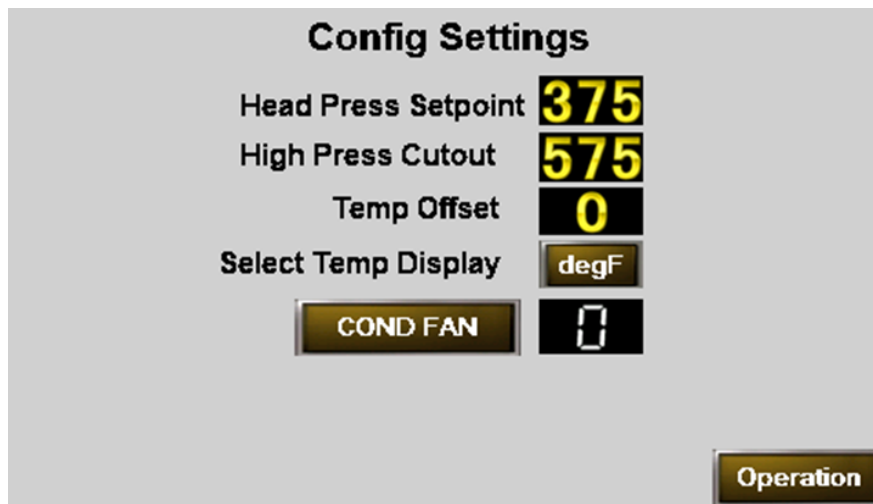

Configuration Settings Screen – Password protected to set initial system settings
Head Press Setpoint – Target pressure that condenser fan will adjust to maintain
High Press Cutout – Pressure that system should not run above and will shut down
Low Press Cutout – Pressure that system should not run below and will shut down
Temp Offset – Temperature offset above setpoint when system will start
Select Temp Display – Selects temperature display units (Celsius or Fahrenheit)
COND FAN – Runs condenser fan in manual mode for testing

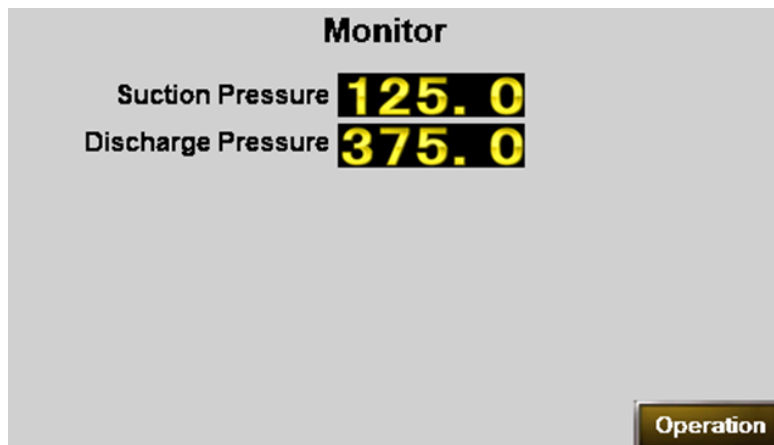

Monitor Screen – Monitor the Suction (Low) Pressure and Discharge (High) Pressure.

Operation and Service

Designed Performance Features

Air conditioning system design requirements:

1. To be located outside of the conditioned space by the use of 2 -14 inch flexible supply air ducts and 3 -14 inch flexible return air ducts.
2. To operate in outdoor temperatures from 0°F to 100°F.
3. To operate from local utility power, generated power, or transformer power.
4. To operate immediately, no warm up time required.

Refrigerant Circuit Components

1. A fully hermetic scroll compressor with over temperature protection. The scroll compressor is unique in its ability to start in a flooded liquid state and run with liquid feedback for short periods of time, although it is not recommended to operate under these conditions continually because of lubrication concerns.
2. Vibration absorbers in the compressor suction and discharge lines to minimize working stress on the refrigerant plumbing.
3. A condenser cooled by an electronically commutated (EC) fan.
4. A liquid line filter/dryer to absorb moisture and contaminants.
5. A liquid line sight glass for monitoring the refrigerant charge and moisture content.
6. An external equalized thermal expansion valve to properly adjust the refrigerant flow rate to the evaporator coil for the current heat load conditions.
7. An evaporator coil to absorb heat from the conditioned air.
8. A hot gas bypass valve for capacity control and to maintain a set suction pressure of 50-52 psig. This valve is plumbed from the discharge line to the inlet of the evaporator coil, allowing hot refrigerant gas to mix with the cool refrigerant liquid and not to overheat the compressor.
9. High and low pressure switches, used as a safety, to shut down the compressor if discharge pressure rises above the cutout limit setting or if the suction pressure drops below the cutout limit.

All of the refrigerant circuit components are standard "off the shelf" and are easily recognized by a certified refrigeration technician.

For operation and service concerns please call:



440-658-2020

Troubleshooting

Caution must be taken when troubleshooting the electrical circuit and should only be performed by a trained service technician.

Generally, troubleshooting will begin by viewing the Fault screen on the Operator Control Panel.

INDICATION	POSSIBLE CAUSE	CORRECTIVE ACTION
Nothing operates	Main power Control power	Check voltage and phasing Check transformer and fusing
Phase Monitor Fault	Incorrect phasing Poor Voltage	Switch two of the main power cables Check for correct supply voltage
Blower Fault	Breaker tripped Motor failure	Find cause, reset breaker Verify 480V 3ph is present and 0-10VDC control voltage is present, replace blower motor
Condenser Fan Fault	Breaker tripped Motor failure	Find cause, reset breaker Verify 480V 3ph is present and 0-10VDC control voltage is present, replace condenser motor
High Pressure Cutout Fault	High pressure trip	Check condenser fan operation Check for restricted condenser air flow Check for refrigerant over charge Press High Pressure Fault to reset.
Motor Overload Fault	Compressor overheated	Allow compressor to cool down
High Pressure SW Fault	Mechanical High Pressure switch tripped	Allow High Pressure to drop below 500PSIG Reset mechanical High Pressure switch
Low Pressure SW Fault	Mechanical Low Pressure switch tripped	Check for refrigerant charge Fault will correct when pressure is above 70PSIG
Only blower operates	Thermostat No call for cooling	Verify correct control temp is selected Verify Setpoint is below current control temp

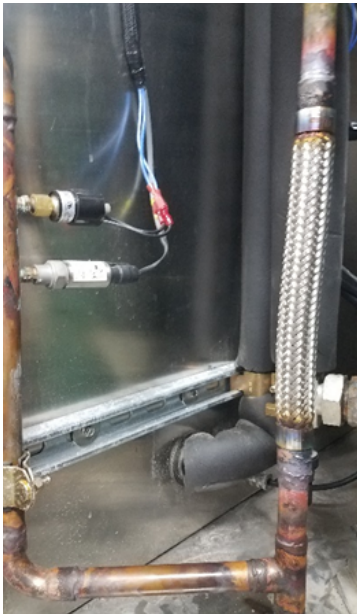

High Pressure and low pressure switches are located in the compressor compartment. The high pressure switch (left picture) must be physically reset if pressure exceeds 600psi. The low pressure switch (right picture) will reset automatically when pressure is above 80psi.

Electrical Schematic

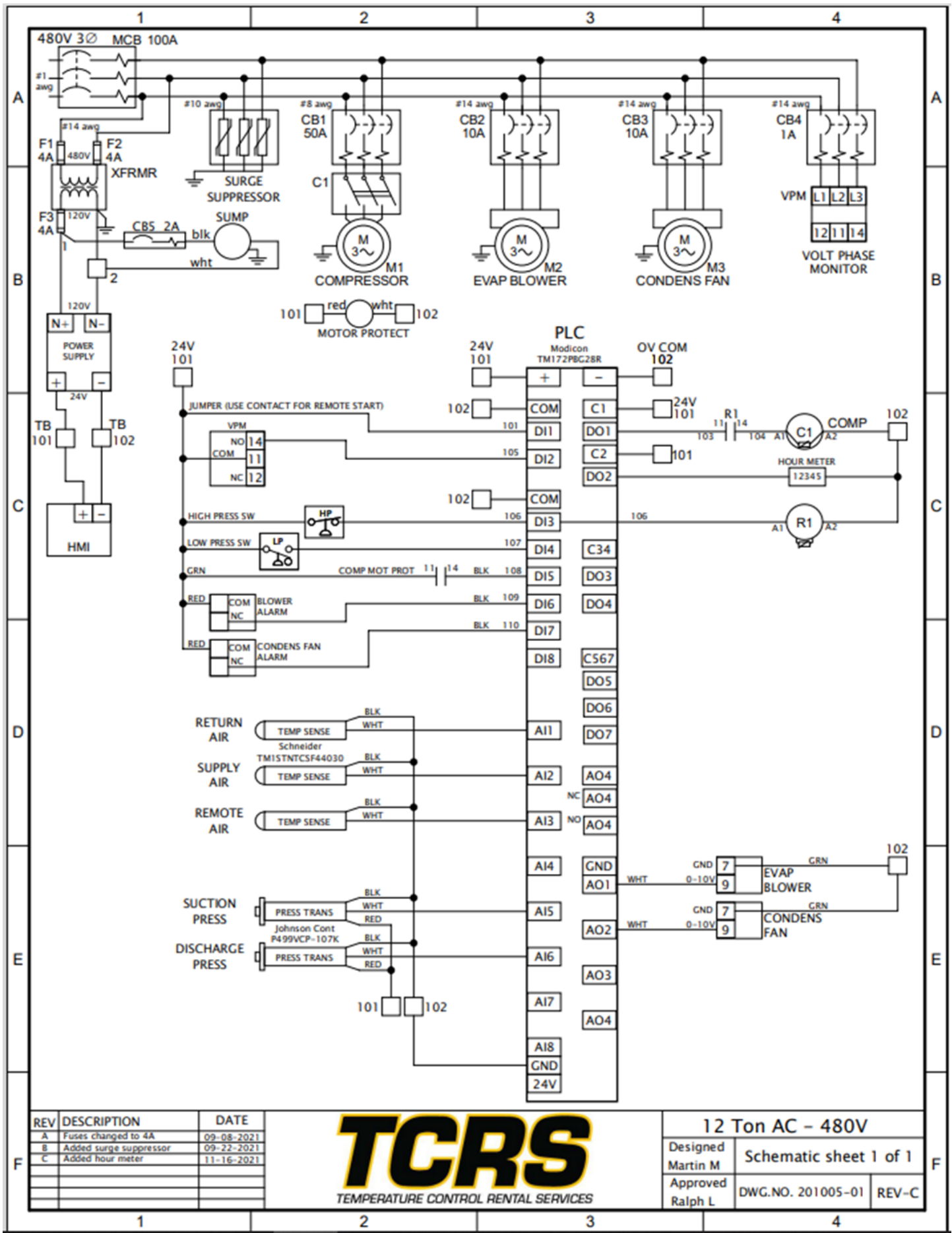

REV	DESCRIPTION	DATE
A	Fuses changed to 4A	09-08-2021
B	Added surge suppressor	09-22-2021
C	Added hour meter	11-16-2021



12 Ton AC - 480V	
Designed Martin M	Schematic sheet 1 of 1
Approved Ralph L	DWG.NO. 201005-01 REV-C

Electrical Panel Layout

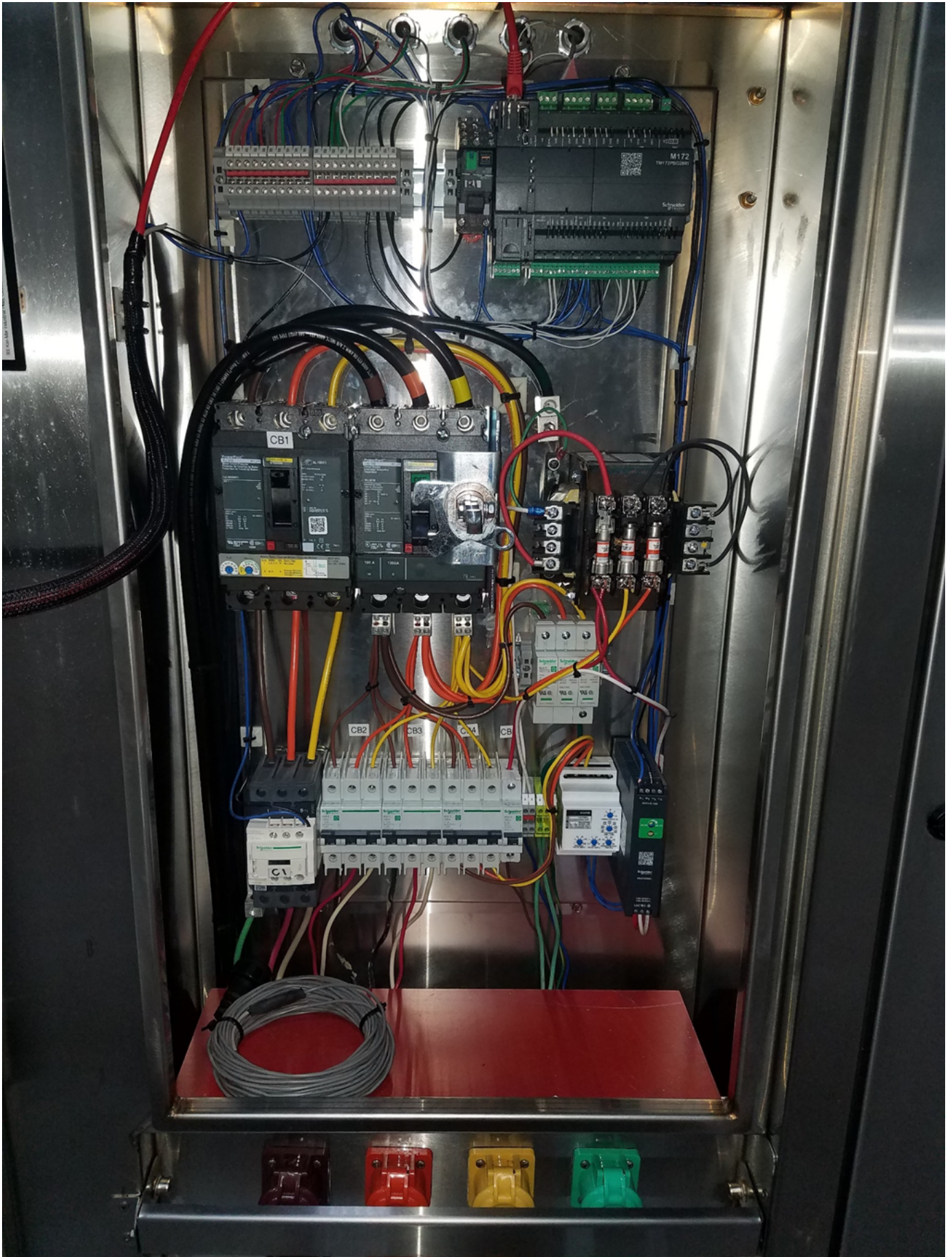

Piping layout

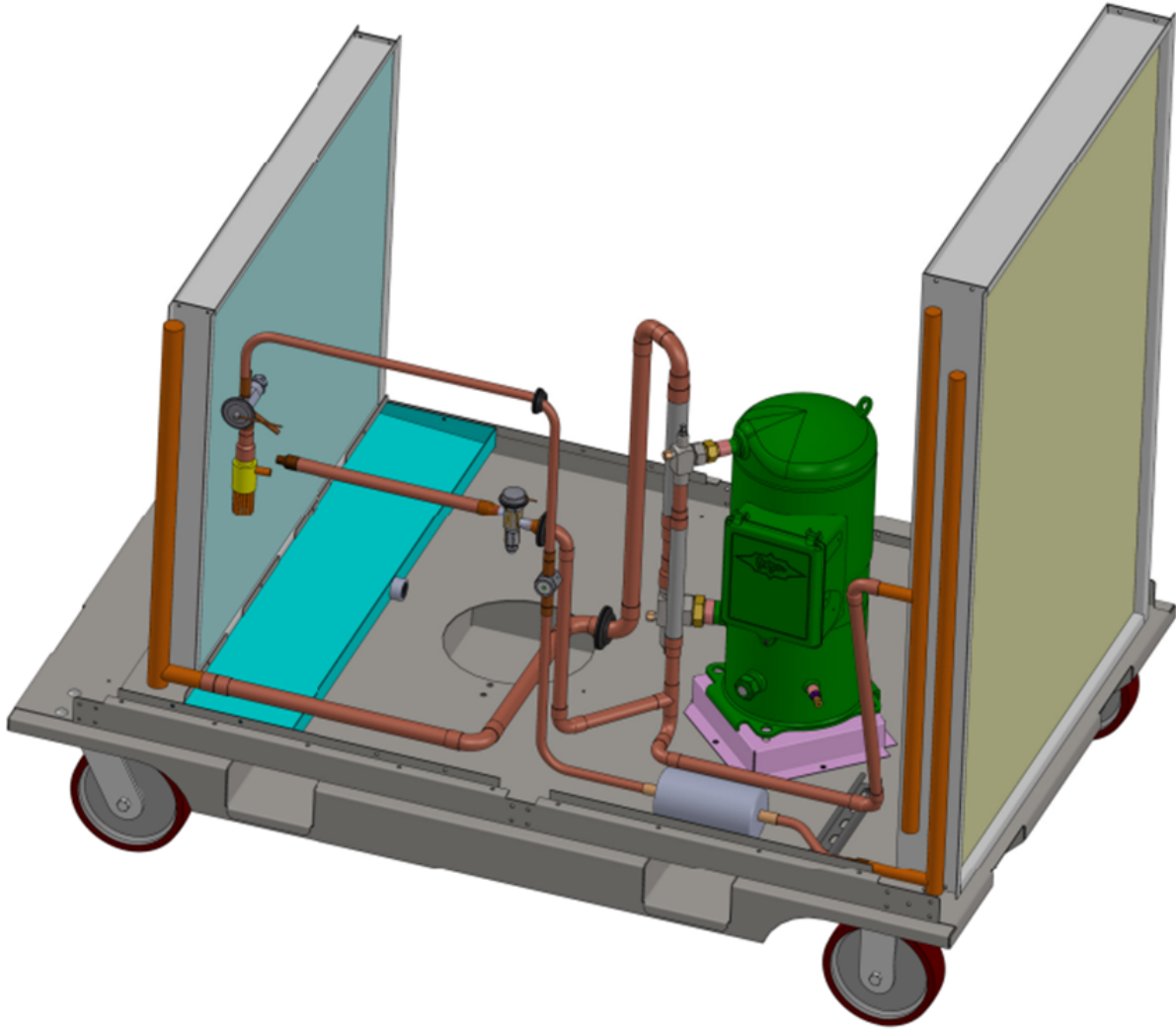

Structural\Sheet Metal BOM

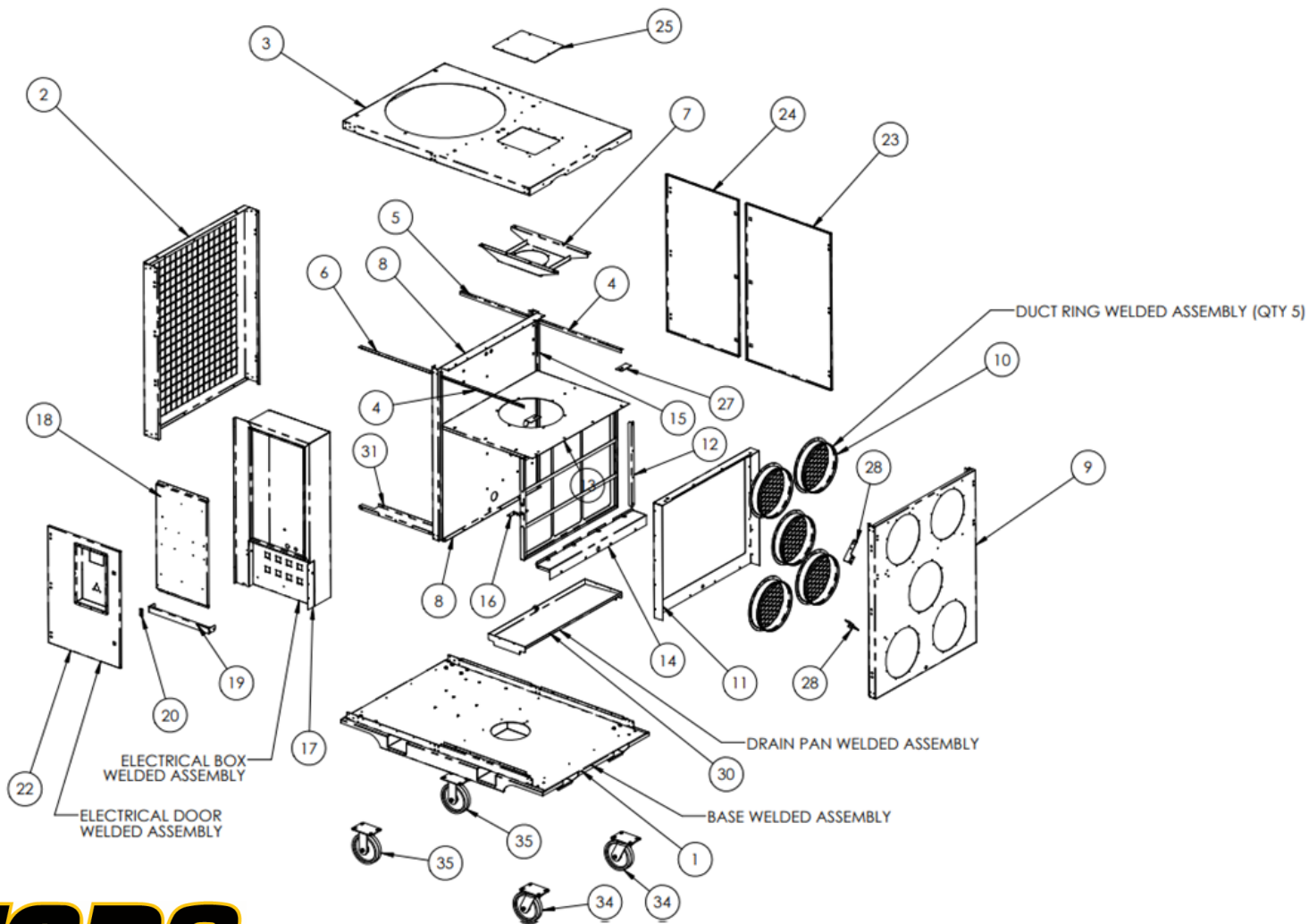
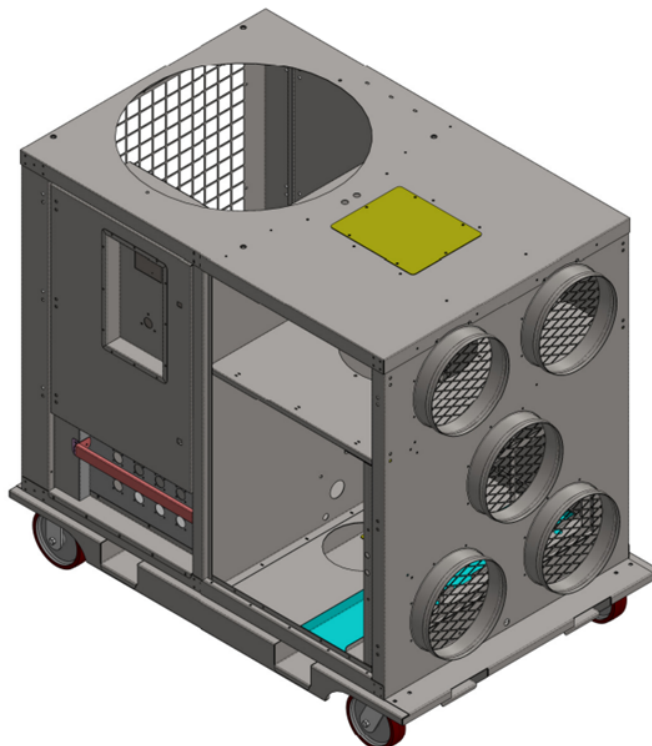

ITEM NO.	PART NUMBER	DESCRIPTION	
1	KT-00036	WELDMENT, BASE, 12T	1
2	FB-00191	PANEL, CONDENSER END, 12 AC	1
3	FB-00180	TOP, STAINLESS, 12T	1
4	FB-00273	FLANGE, TOP DOOR, 12T	2
5	FB-00273-1	FLANGE, TOP DOOR, 12T	1
6	FB-00273-2	FLANGE, TOP DOOR, 12T	1
7	FB-00182	BRACKET, BLOWER MOUNT, SS, 12T	1
8	FB-00184	WALL, DIVIDER, SS, 12T	1
9	FB-00185	PANEL, DUCT COLLAR, SS, 12T	1
10	KT-00033	WELDMENT, 14" DUCT RING, 304 SS	5
11	FB-00192	COIL MOUNT, SS, 12T	1
12	FB-00217	ANGLE, FILTER STOP, SS, 12T	1
13	FB-00186	PANEL, BLOWER INTAKE, SS, 12T	1
14	FB-00193	FILTER CHANNEL, LOWER, 12 AC	1
15	FB-00199	ANGLE, DOOR JAM, SS, 12T	2
16	FB-00282	BRACKET, COND PUMP, 12 AC	1
17	KT-00039	WELDMENT, ELECTRICAL BOX, SS, 12T	1
18	FB-00189	PANEL, ELECTRICAL, 12T	1
19	FB-00281	BAR,CAMLOC LOCKOUT, 12 AC	1
20	FB-00280	BRACKET,CAMLOC LOCKOUT, 12 AC	1
21	FB-00212	FLANGE, ELECTRICAL BOX, SS, 12T	1
22	KT-00041	ASSEMBLY, ELECTRICAL PANEL DOOR, 12T	1
23	FB-00210	DOOR, EVAP, SS, 12T	2
24	FB-00211	DOOR, COND, SS, 12T	1
25	FB-00213	COVER, CONDENSER FAN MTR, 12 AC	1
26	FB-00183	COIL MOUNT, TOP, 12T	1
27	FB-00214	FILLER PLATE, EVAP, 12T	2
28	FB-00216	BRACKET, SS, TEMP SENSOR MTG	2
29	FB-00219	BRACKET, FILTER DRIER MOUNTING	1
30	KT-00055	WELDED ASSEMBLY, DRAIN PAN, 12T AC	1
31	FB-00284	PLATE, POWER PANEL BOTTOM, 12T	1
32	FB-00197	FILTER RACK, SS, 12T	1
33	FB-00198	STRAP, FILTER RACK, SS, 12T	2
34	2703T62	CASTER, 8" DIA, SWIVELING	2
35	3703T72	CASTER, 8" DIA FIXED	2